

Symptoms:

Some customers have experienced binding and limited steering travel on Series 5 Pro Series machines.

Details:

If after inspection the steering linkage appears to be in working order, the issue may be caused by a potential group of compromised DU bearings in the caster bores.

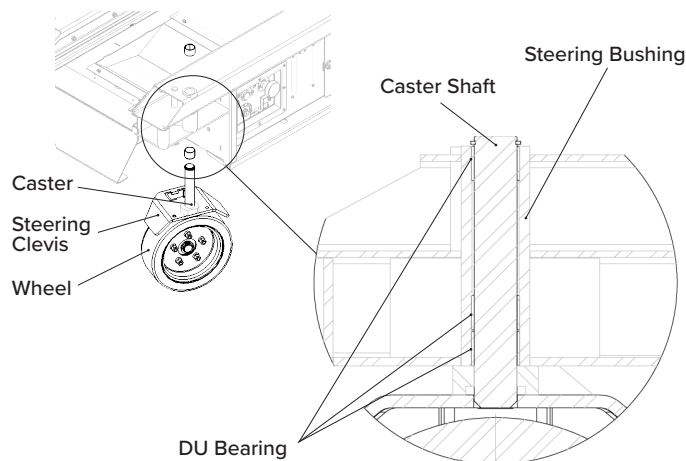

Part Number(s) needed for this service instruction:

Description	Part No.	QTY
DU BEARING	HARD-001	4

Units Applicable:

PS-1030

Serial Number Range:
PS-10-50001 - PS10-50017

PS-1430

Serial Number Range:
PS14-50001 - PS14-50183
(Excluding PS14-50034 - PS14-50036)

PS-1930

Serial Number Range:
PS19-50001 - PS19-50308
(Excluding PS19-50198 - PS19-50202)

Machines Under Warranty:

For machines under warranty, Hy-Brid lifts will reimburse the customer for the cost of the (4) DU Bearings as well as 1 hour of labor to install at an hourly rate of \$65.

Tools Needed:

- Snap Ring Pliers
- Needle Nose Pliers
- DU Punch (112-90-530-03)
- **DU Steering Tool Kit (112-90-551-50):**
The DU Steering Tool Kit is comprised of custom tools created by Hy-Brid Lifts that will be loaned out on an as needed basis.

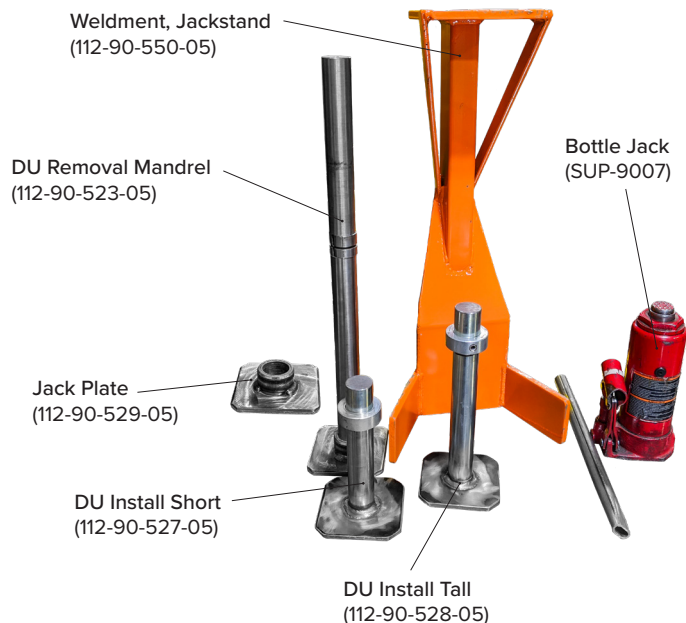

Instructions:

1. Turn key switch off
2. Turn master disconnect off



3. Place lift up on industrial saw horses.
4. Remove the wheel prior to removing the caster by removing the snap ring from the wheel axle.

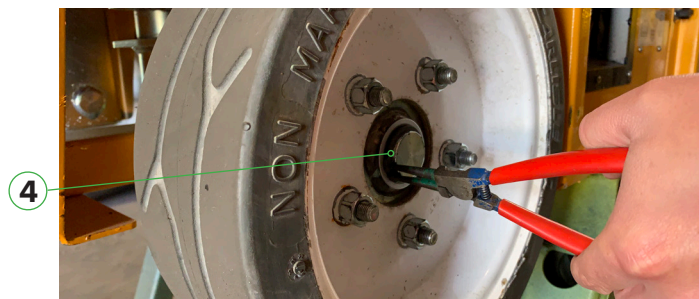

5. Remove locking cotter pin from steering clevis using needle nose pliers.

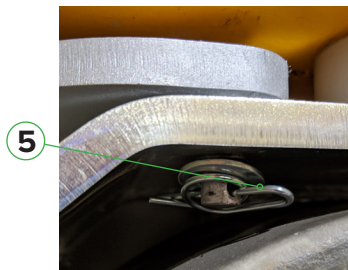

6. Remove snap ring from caster shaft using snap ring pliers.



7. Using a twisting motion, gently pull the caster down and out of the steering bushing. Use caution as the caster is relatively heavy.

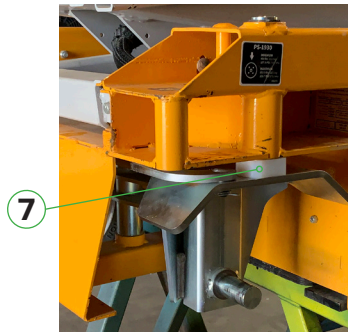

8. Inspect the caster shaft and DU bearings inside the steering bushing for abnormal wear. If the DU material is depositing onto the caster shaft, this is an indication that the DU bearings have been compromised and should be replaced.

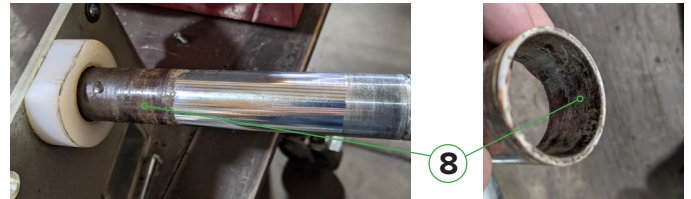

9. To begin replacement of the DU bearings, insert the Jackstand into the side of the base facing downwards.



10. Unscrew the ends of the DU removal mandrel enough to allow the center to retract. The center is held together with an O-ring that compresses the center as the tapered ends are unscrewed.

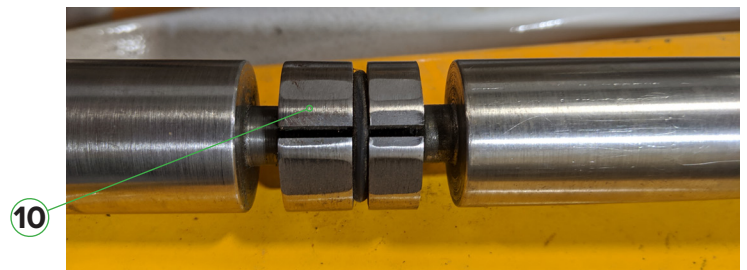

11. Insert the DU removal mandrel into the bore of the caster bushing, short shaft down, long shaft up.
12. When the expandable center is between the top and bottom DU bearings, screw the ends of the mandrel together by hand until the assembly bottoms out and the center is fully expanded.
13. Place the bottle jack on the jack frame, the mandrel foot on the bottle jack, and insert the DU mandrel into the mandrel foot.



14. Using steady pressure, pump the bottle jack and push the DU bearing out of the top of the steering bushing. There will be a single bearing.



15. Remove the bottle jack, allow the DU mandrel to rest on the lower DU bearings in the steering bushing, and remove and replace the jack frame in the up position.



16. Place the mandrel foot on the mandrel, and the bottle jack on the mandrel foot.



17. Using steady pressure, pump the bottle jack and push the DU bearings out of the bottom of the steering bushing. There will be a total of (2) bearings.*



*With the top DU out, in rare cases the bottom DU's may not extract using the mandrel and hydraulic pressure. If this is the case, the DU punch may be inserted from the top and a heavy steel hammer used to drive out the 2 lower DU bearings.

18. Verify the bore of the steering bushing is clean and free of debris.
19. Press in new DU bearings starting with the top bearing. It is important to keep the bearings straight and to use slow and steady pressure to seat them into their bores.
20. Place the jack frame in the up position. Set the fresh DU bearing (HARD-001) straight into the bore of the steering bushing. Place the DU Install Short into the DU. Place the bottle jack on the DU Install Short and in the jack frame.



21. Using steady pressure, pump the bottle jack and push the DU bearing in until it is seated flush.



22. Place the jack frame in the down position. Set the fresh DU bearing (HARD-001) straight into the bore of the steering bushing. Place the DU Install Long into the DU. Place the bottle jack on the jack frame and under the DU Install Long.



23. Using steady pressure, pump the bottle jack and push the DU bearing in until it is seated flush. Note: (2) DU bearings were removed from the bottom of the steering bushing but only (1) is required to be installed.
24. Once the DU bearings have been replaced, the caster shafts must be cleaned up before reinstalling the casters. A wire wheel, emery cloth, and/or parts cleaner may be used to gently remove DU bearing deposits and corrosion. The finish on the shaft should be as smooth and concentric as possible. Minor pitting is acceptable as long as there are no raised areas.



SERVICE INSTRUCTION: 08SEP2020

PRO SERIES STEERING BINDING - DU BEARINGS

SI-Steering Binding_DU Bearings.pdf

HY-BRID LIFTS™
BY CUSTOM EQUIPMENT LLC

25. The caster may be reinstalled using a gentle twisting motion as the caster shaft is seated into the bore. Reinstall the snap ring to retain the caster and the locking cotter pin for the steering.
26. Repeat steps 4 through 25 for the opposite side.
27. Turn Master disconnect switch on and Turn Key on.
28. Check steering for full travel without binding.